

Model EGCS3-D Triaxial Accelerometer

DC Response
10,000 g Overrange Stops
High Sensitivity
Shielded Cable

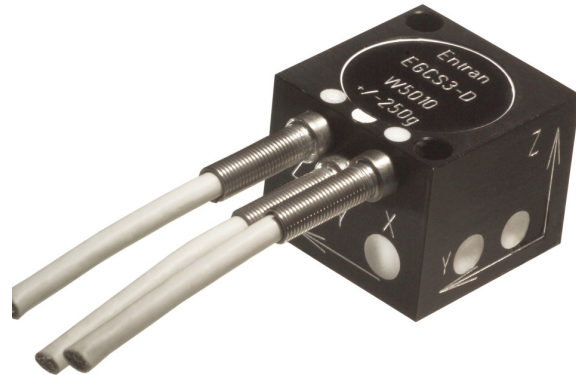

The **Model EGCS3-D** triaxial accelerometer is available in ranges from ± 5 g through ± 5000 g. With overrange limit to $\pm 10,000$ g and spring strain relief, this rugged device is ideal for offshore, downhole and shock testing applications. Its small size and screw mounting ensure ease of installation while its low power requirements and DC output facilitate integration into data acquisition and monitoring systems. The EGCS3 also features CE Conformance to EN 61010-1, EN 50081-1 and EN 50082-1.

dimensions

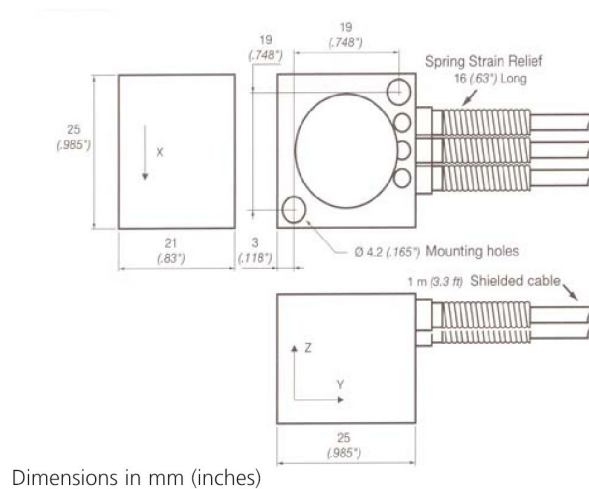

FEATURES

- 3 Axes
- Cable Strain Relief
- Static and Dynamic Measurement
- Frequency Response through 4000 Hz
- $\pm 1\%$ Non-Linearity
- -40°C to $+120^\circ\text{C}$ Operating Temperature Range
- 10,000 g Overrange Protection

APPLICATIONS

- Blast Testing
- Machine Control
- Performance Testing
- Engine Testing

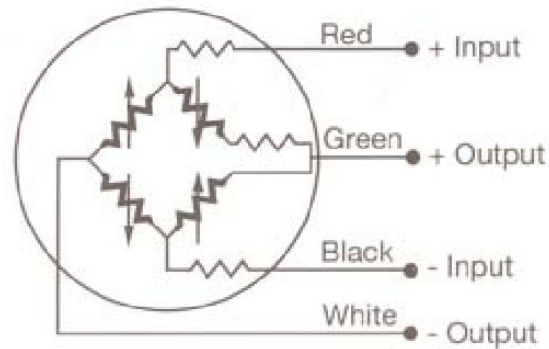

Model EGCS3-D Accelerometer

performance specifications

All values are typical at 24°C and 15 Vdc excitation unless otherwise stated. Measurement Specialties, Inc. reserves the right to update and change these specifications without notice.

Parameters

DYNAMIC

Range (g)	5	10	25	50	100	250	500	1000	2500	5000
Sensitivity (mV/g)	30	20	8	4	2	0.8	0.4	0.2	0.08	0.04
Nominal Freq. Response (Hz)	0-150	0-200	0-400	0-600	0-900	0-1300	0-1750	0-2500	0-3500	0-4000
Nominal Resonance (Hz)	300	400	800	1200	1800	2600	3500	5000	7000	8000
Non-Linearity (%)					±1					
Transverse Sensitivity (% MAX)					2					
Zero Acceleration Output (±mV)					15					
Thermal Zero Shift (50°C/100°F)					±2.0 mV					
Thermal Sensitivity Shift (50°C/100°F)					±2.5%					
Damping Ratio (Nominal)					0.7					

ELECTRICAL

Voltage Excitation (Vdc)	15
Input Resistance (Ohms)	2K
Output Resistance (Ohms)	1K
Cable Output Connections	
Red	+EXC
Black	-EXC
Green	+OUT
White	-OUT

PHYSICAL

Case Material	Aluminum
Cable Length (meter/feet)	1 / 3.28
Weight (grams)	<50
Mounting	Screw

ENVIRONMENTAL

Shock Limit Sensitive Axis (g)	500	1000	2000	5000	10000	10000	10000	10000	10000	10000
Operating Temperature (°C/°F)	-40 to 120/-40 to 250									
Compensated Temperature (°C/°F)	20 to 80/70 to 170									

The information in this sheet has been carefully reviewed and is believed to be accurate; however, no responsibility is assumed for inaccuracies. Furthermore, this information does not convey to the purchaser of such devices any license under the patent rights to the manufacturer. Measurement Specialties, Inc. reserves the right to make changes without further notice to any product herein. Measurement Specialties, Inc. makes no warranty, representation or guarantee regarding the suitability of its product for any particular purpose, nor does Measurement Specialties, Inc. assume any liability arising out of the application or use of any product or circuit and specifically disclaims any and all liability, including without limitation consequential or incidental damages. Typical parameters can and do vary in different applications. All operating parameters must be validated for each customer application by customer's technical experts. Measurement Specialties, Inc. does not convey any license under its patent rights nor the rights of others.

ordering info

EGCS3 - D - 100 - /L2M/C
 Range Options
 C
 LOOF or LOOM

COMPENSATED TEMPERATURE RANGES:	STANDARD	= 20°C to 80°C (70°F to 170°F)
	Z*	= Non-standard, contact factory
EXCITATION VOLTAGE:	STANDARD	= 15VDC
SPECIAL CABLE LENGTH:	LOOF	= Replace "00" with total length in feet.
	LOOM	= Replace "00" with total length in meters.
CONNECTOR WIRED TO CABLE:	C	= Microtech type male or equivalent