

ELHS Load Cell



- **Ranges: 200 through 10,000 lbf (2.5KN to 50KN)**
- **Ultra compact button or threaded stud**
- **Output FSO: 200 mV FSO typical**
- **High resolution**
- **Compression or tension/compression**
- **Low deflection, low mass**

DESCRIPTION

The ELHS load cell is a compact package able to fit into many applications where others cannot. The low noise Wheatstone bridge consists of piezoresistive strain gages which provide 200 mV of typical full scale output. When compact design, extreme stiffness and superior resolution are required, the ELHS load cell is the sensor for your application. The ELHS is provided with either SAE or metric threads for tension and compression applications.

Care should be exercised to isolate your ELHS from off-axis loads. The ELHS is a Poisson column design providing low full scale input deflection and superior resolution. Designed specifically to provide high resolution and low deflection. The ELHS can be configured with a variety of options to fine tune the instrument to your application: select from several standard compensated temperature ranges, input voltages, lead lengths or specify entirely unique combinations of these options.

FEATURES

- Low mass compression style or tension compression with studs
- From 200 to 10000 lbf ranges (2.5KN to 50KN)
- Low noise
- High reliability

APPLICATIONS

- Assembly forces
- Applications requiring ultra fast response
- Tool forces
- Thrust measurements
- Measurements requiring low sensor deflection and high resolution
- Product validation testing

ELHS Load Cell

STANDARD RANGES

Ranges		Overrange	Body style		Output "FSO" (nom.)
N	lbf		Compression	Tension & Compression	
1K	200	1.5 x FS	ELHS-B1	ELHS-T1	200 mV
2.5K	500	1.5 x FS	ELHS-B1	ELHS-T1	200 mV
5K	1K	1.5 x FS	ELHS-B1	ELHS-T1	200 mV
10K	2K	1.5 x FS	ELHS-B4	ELHS-T4	200 mV
25K	5K	1.5 x FS	ELHS-B4	ELHS-T4	200 mV
50K	10K	1.5 x FS	ELHS-B6	ELHS-T6	200 mV

Note: type B units: positive output in compression. Type T units: positive output in tension.

PERFORMANCE SPECIFICATIONS

PARAMETERS	VALUES	NOTES
Supply voltage	15VDC	
Input resistance	1500Ω nom.	
Output resistance	500Ω nom.	
Non-repeatability	± 0.25 % FSO	
Combined non-linearity and hysteresis	±0.5%FSO	
Thermal Zero Shift "TZS"	±0.02%FSO /°C	
Thermal Sensitivity Shift "TSS"	±0.05% /°C	
Operating temperature	-20°C to 80°C	
Compensated temperature	20°C to 80°C	See option table for other temperatures
Zero offset at 23°C	± 10mV typ.	
CE conformance according to	EN 61010-1, EN 50081-1, EN 50082-1	

ELHS Load Cell

DIMENSIONS

ELHS-B1, -B4 & -B6

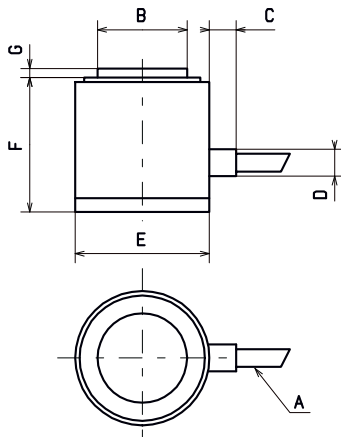

ELHS-T1, -T4 & T6

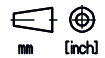
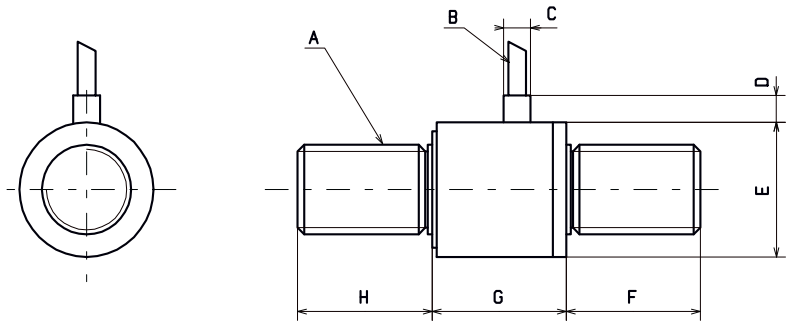

ITEM	ELHS-B1 200 to 1,000Lb 1KN to 5KN	ELHS-B4 2KLb to 5KLb 10KN to 25KN	ELHS-B6 10KLb 50KN
A	3m (10 ft) shielded cable	3m (10 ft) shielded cable	3m (10 ft) shielded cable
B	ø 10 (0.39")	ø 20 (0.78")	ø 28 (1.1")
C	3 (0.12")	3 (0.12")	6 (0.24")
D	ø 3 (0.12")	ø 3 (0.12")	ø 5 (0.2")
E	ø 15 (0.59")	ø 25 (0.98")	ø 35 (1.38")
F	15 (0.59")	25 (0.98")	35 (1.38")
G	1 (0.04")	1 (0.04")	1 (0.04")

ITEM	ELHS-T1 200 to 1,000Lb 1KN to 5KN	ELHS-T4 2KLb to 5KLb 10KN to 25KN	ELHS-T6 10KLb 50KN
A	-T1E : 3/8-24 UNF -T1M : M10x1.5	-T4U : 5/8-18 UNF -T4M : M16x2	-T6U : 3/4-16 UNF -T6M : M20x2.5
B	3m (10 ft) shielded cable	3m (10 ft) shielded cable	3m (10 ft) shielded cable
C	ø 3 (0.12")	ø 3 (0.12")	ø 5 (0.2")
D	3 (0.12")	3 (0.12")	6 (0.24")
E	ø 15 (0.59")	ø 25 (0.98")	ø 35 (1.38")
F	15 (0.59")	25 (0.98")	30 (1.18")
G	15 (0.59")	25 (0.98")	30 (1.18")
H	15 (0.59")	25 (0.98")	30 (1.18")

INSTALLATION

CONNECTIONS

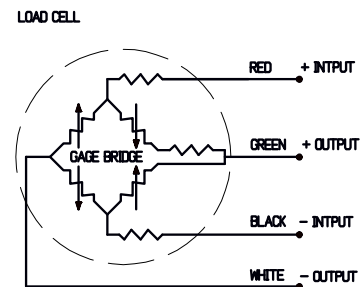
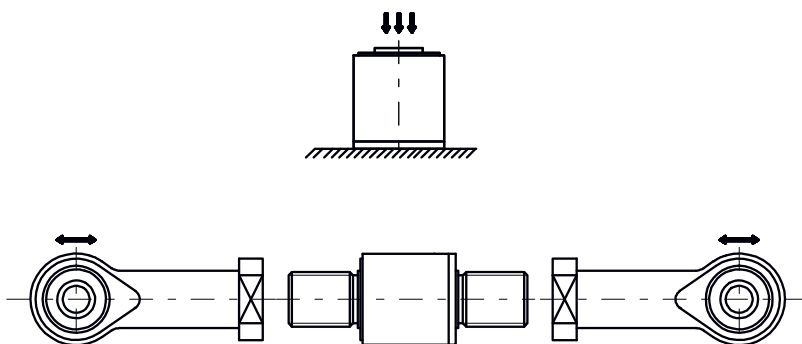

ELHS Load Cell

OPTIONS AND ACCESSORIES

OPTIONS	CODES	DESCRIPTIONS
Compensated temperature ranges	Z0	-40°C to 20°C
	Z1	-20°C to 40°C
	Z2	0°C to 60°C
	Z*	Non-standard, contact MEAS
Supply voltage	V00	Replace "00" with voltage between 1 and 14.
Special cable length	L00F	Replace "00" with total length in feet with Lb range.
	L00M	Replace "00" with total length in meters with N range.
Connector wired to cable	C	Microtech type male or equivalent (w/o mate)
	RS	RJ telephone type male (w/o mate)
Calibration	AC	Alternate calibration: units with studs are calibrated in tension by default. Option AC provides compression calibration in addition to tension calibration

ORDERING INFORMATION

Model	-	Body	Thread Type	-	Range & Unit ⁽¹⁾		-	/Options
ELHS	-	B1/T1	M : Metric	-	1KN	200L	-	/Z0, Z1, Z2, or Z*
		B1/T1	U, E : SAE		2.5KN	500L		/V1 thru V14
		B1/T1			5KN	1KL		/L00F or L00M
		B4/T4			10KN	2KL		/C or RS
		B4/T4			25KN	5KL		/AC
		B6/T6			50KN	10KL		

(1)Note : L=lbf ; N=Newton. Metric threaded units must have Newtons range specified. SAE threaded units must have lbf range specified. Metric threaded units must have cable lengths specified in meters. SAE threaded units must have cable lengths specified in inches.

Example of model construction: ELHS-B1-5KN-/Z1 /L3M/C

NORTH AMERICA

Measurement Specialties
 45738 Northport Loop West
 Fremont, CA 94538
 Tel: 1-800-767-1888
 Fax: 1-510-498-1578
 Sales: pfg.cs.amer@meas-spec.com

EUROPE

Measurement Specialties
 (Europe), Ltd.
 26 Rue des Dames
 78340 Les Clayes-sous-Bois, France
 Tel: +33 (0) 130 79 33 00
 Fax: +33 (0) 134 81 03 59
 Sales: pfg.cs.emea@meas-spec.com

ASIA

Measurement Specialties
 (China), Ltd.
 No. 26 Langshan Road
 Shenzhen High-Tech Park (North)
 Nanshan District, Shenzhen 518107
 China
 Tel: +86 755 3330 5088
 Fax: +86 755 3330 5099
 Sales: pfg.cs.asia@meas-spec.com

The information in this sheet has been carefully reviewed and is believed to be accurate; however, no responsibility is assumed for inaccuracies. Furthermore, this information does not convey to the purchaser of such devices any license under the patent rights to the manufacturer. Measurement Specialties, Inc. reserves the right to make changes without further notice to any product herein. Measurement Specialties, Inc. makes no warranty, representation or guarantee regarding the suitability of its product for any particular purpose, nor does Measurement Specialties, Inc. assume any liability arising out of the application or use of any product or circuit and specifically disclaims any and all liability, including without limitation consequential or incidental damages. Typical parameters can and do vary in different applications. All operating parameters must be validated for each customer application by customer's technical experts. Measurement Specialties, Inc. does not convey any license under its patent rights nor the rights of others.