

Model 1201F Accelerometer

DC Response
Durable Cable
Reliable Performance
Low Cost



The Model 1201F Accelerometer

is a small, compact uniaxial device designed for vehicle impact and road testing. Its mechanical overload stops provide high shock protection in rugged applications. Featuring ranges from 50 g to 1000g and frequency response to 3000 Hz, this sensor is easily mounted in hard to get places on vehicles under test.

FEATURES

- 2nd GEN MEMS Sensing Element
- 1000 g Full Scale Range
- 2-10 VDC Excitation for Maximum Flexibility
- 0-50 °C Temperature Range
- ±40 mV Zero Measurand Output
- Gas Damping
- Connector Options
- Mechanical Overload Stops
- Designed for Screw Mounting

APPLICATIONS

- Crash Testing
- Impact Testing
- Off-Road Testing
- Road Testing

dimensions

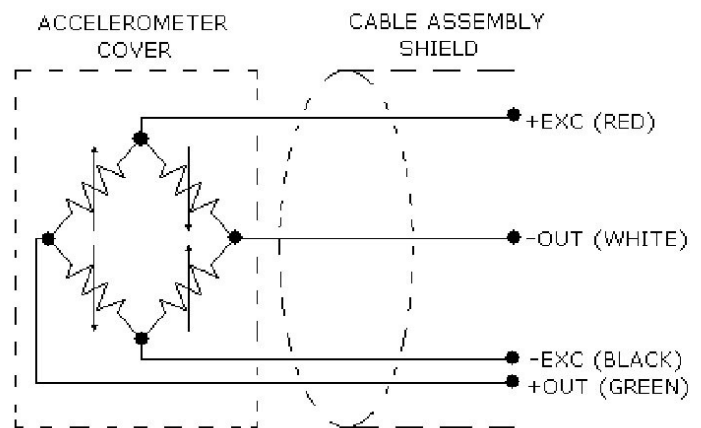
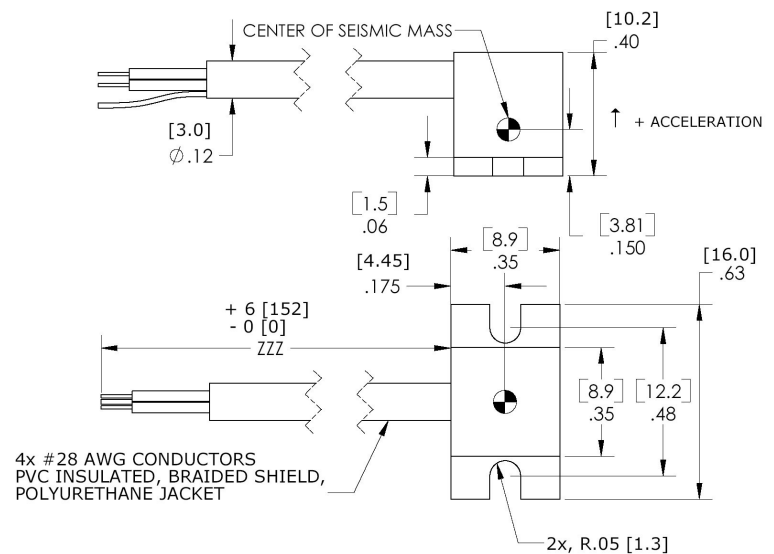

Model 1201F Accelerometer

performance specifications

All values are typical at $\pm 24^{\circ}\text{C}$, 100 Hz and 10 Vdc excitation unless otherwise stated. Measurement Specialties reserves the right to update and change these specifications without notice.

Parameters						Notes
DYNAMIC						
Range(g)	± 50	± 100	± 200	± 500	± 1000	
Sensitivity (mV/g)	2	.9	.9	.4	.15	
Frequency Response (Hz)	0-800	0-1500	0-1800	0-2700	0-3000	± 1 dB
Resonant Frequency (Hz)	2000	3000	4000	6000	7000	
Non-Linearity (% of reading)	± 1	± 1	± 1	± 1	± 1	
Transverse Sensitivity (%)	3 %	3 %	3 %	3 %	3 %	
Thermal Zero Shift (%FSO/ $^{\circ}\text{C}$)	± 0.05	± 0.05	± 0.05	± 0.05	± 0.05	From 0 to $+50^{\circ}\text{C}$
Thermal Sensitivity Shift (%/ $^{\circ}\text{C}$)	± 0.2	± 0.2	± 0.2	± 0.2	± 0.2	From 0 to $+50^{\circ}\text{C}$
ELECTRICAL						
Zero Acceleration Output (mV)	$< \pm 40$	$< \pm 40$	$< \pm 40$	$< \pm 40$	$< \pm 40$	
Excitation (Vdc)	2 to 10	2 to 10	2 to 10	2 to 10	2 to 10	
Input Resistance	3500-4800	3500-4800	3500-4800	3500-4800	3500-4800	Measured between +EXC and -EXC
Output Resistance (Ω)	2700-4800	2700-4800	2700-4800	2700-4800	2700-4800	Measured between +OUT and -OUT
Insulation Resistance ($M\Omega$)	> 100	> 100	> 100	> 100	> 100	@50Vdc
Ground Isolation	Isolated from Mounting Surface					
Humidity	Epoxy Sealed					
ENVIRONMENTAL						
Shock Limit (g)	3000	3000	4000	5000	5000	
Operating Temperature ($^{\circ}\text{C}$)	-20 to $+85$					
PHYSICAL						
Case Material	Anodized Aluminum					
Cable (Integral 30 Foot Cable)						4 x 28 AWG Conductors
Cable Jacket						Polyurethane
Weight (grams)	2.5	2.5	2.5	2.5	2.5	Cable Not Included
Mounting	Adhesive / Screw Mount					

The information in this sheet has been carefully reviewed and is believed to be accurate; however, no responsibility is assumed for inaccuracies. Furthermore, this information does not convey to the purchaser of such devices any license under the patent rights to the manufacturer. Measurement Specialties, Inc. reserves the right to make changes without further notice to any product herein. Measurement Specialties, Inc. makes no warranty, representation or guarantee regarding the suitability of its product for any particular purpose, nor does Measurement Specialties, Inc. assume any liability arising out of the application or use of any product or circuit and specifically disclaims any and all liability, including without limitation consequential or incidental damages. Typical parameters can and do vary in different applications. All operating parameters must be validated for each customer application by customer's technical experts. Measurement Specialties, Inc. does not convey any license under its patent rights nor the rights of others.

ordering info

PART NUMBERING Model Number+Range+Excitation+Cable Length+Options

1201F-GGGG-VV-CCCX

| | | | Options
 | | | Cable (360 is 360 inches)
 | | | Excitation (10 is 10 Vdc)
 | | | Range (0100 is 100 g)

Options:

X = None
 D = Deutsch Connector (P/N TBDJ)
 L = Lemo Connector (P/N FGG.18.307.CYCD42)
 T = Tajimi Connector (P/N R05PB5M)

Example: 1201F-1000-10-360X

Standard Configuration: 1000g, 10V Excitation, 360" (30ft) cable, No Options