

Model 4801A Accelerometer



Amplified, Signal Conditioned
Hermetically Sealed
Detachable Cable
10,000g Over-Range Protection

The **Model 4801A** is a true hermetically sealed accelerometer in a rugged stainless steel package. The offers an amplified signal conditioned output in ranges from ± 2 to $\pm 500g$. The model 4801A incorporates enhanced temperature compensation and a gas damped MEMS sensing element for optimum frequency response. Mechanical over-range stops offers shock protection up to 10,000g designed for both static and dynamic measurements in critical applications.



dimensions

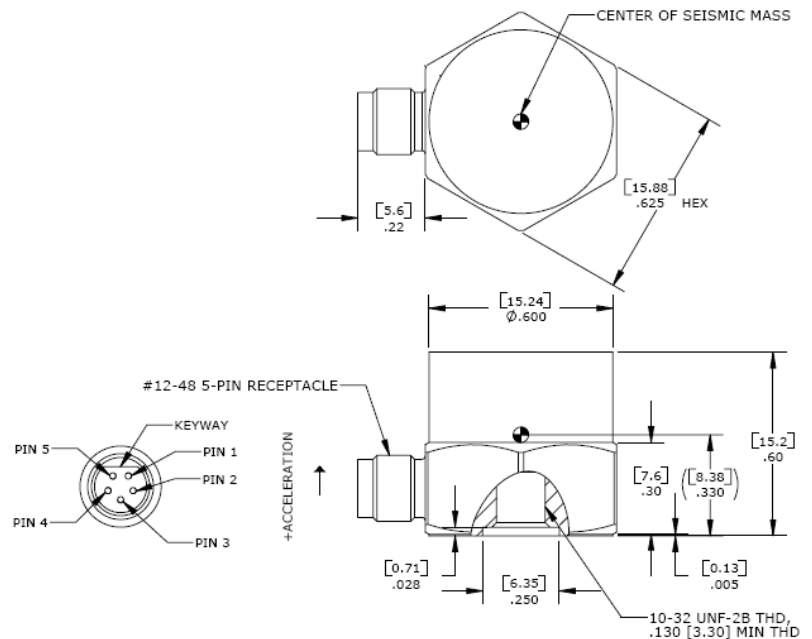

FEATURES

- $\pm 2g$ to $\pm 500g$ Dynamic Range
- Amplified Output
- 8-36Vdc Excitation Voltage
- Gas Damped MEMS Element
- Detachable Cable
- DC to 2000Hz Response
- Stud Mounting

APPLICATIONS

- Vehicle Testing
- Structural Testing
- Test & Instrumentation
- Transportation Measurements
- Environmental Testing

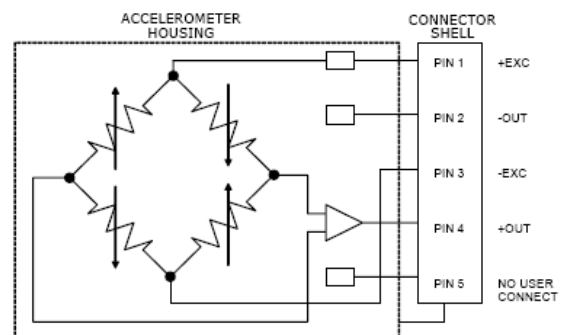

Model 4801A Accelerometer

performance specifications

All values are typical at +24°C, 100Hz and 12Vdc excitation unless otherwise stated. Measurement Specialties reserves the right to update and change these specifications without notice.

Parameters

DYNAMIC

	±2	±5	±10	±20	±50	±100	±200	±500	Notes
Range (g)									
Sensitivity (mV/g)	1000	400	200	100	40	20	10	4	
Frequency Response (Hz)	0-100	0-200	0-300	0-400	0-800	0-1300	0-1500	0-1500	±5%
Natural Frequency (Hz)	700	800	1000	1500	4000	6000	8000	10000	
Non-Linearity (%FSO)	±0.5	±0.5	±0.5	±0.5	±0.5	±0.5	±0.5	±0.5	
Transverse Sensitivity (%)	<3	<3	<3	<3	<3	<3	<3	<3	
Damping Ratio	0.7	0.7	0.7	0.7	0.7	0.7	0.6	0.5	
Shock Limit (g)	10000	10000	10000	10000	10000	10000	10000	10000	

ELECTRICAL

Zero Acceleration Output (mV)	±50	±50	±50	±50	±50	±50	±50	±50	Differential
Excitation Voltage (Vdc)	8 to 36	8 to 36	8 to 36	8 to 36	8 to 36	8 to 36	8 to 36	8 to 36	
Excitation Current (mA)	<5	<5	<5	<5	<5	<5	<5	<5	
Bias Voltage (Vdc)	2.5	2.5	2.5	2.5	2.5	2.5	2.5	2.5	
Output Resistance (Ω)	<100	<100	<100	<100	<100	<100	<100	<100	
Insulation Resistance (MΩ)	>100	>100	>100	>100	>100	>100	>100	>100	@100Vdc
Turn On Time (msec)	<100	<100	<100	<100	<100	<100	<100	<100	
Residual Noise (µV RMS)	500	300	350	400	400	400	400	400	Passband
Ground Isolation	Isolated from Mounting Surface								

ENVIRONMENTAL

Thermal Zero Shift (%FSO/°C)	±0.008	±0.008	±0.008	±0.008	±0.008	±0.008	±0.008	±0.008	Typical
Thermal Sensitivity Shift (%/°C)	±0.010	±0.010	±0.010	±0.010	±0.010	±0.010	±0.010	±0.010	Typical
Operating Temperature (°C)	-55 to 125								
Compensated Temperature (°C)	-55 to 125								
Storage Temperature (°C)	-55 to 125								

PHYSICAL

Case Material	Stainless Steel
Cable	Not Applicable
Weight (grams)	22
Mounting	#10-32 to #10-32 Mounting Stud (included)
Mounting Torque	18 lb-in (2.0 N-m)
AWG	Not Applicable

Wiring color code: +Excitation = Pin 1; -Excitation = Pin 3; +Output = Pin 4; -Output = Pin 2; Programming = Pin 5 (Pin 5 is used for programming and is not to be connected)

Supplied accessories: AC-D02298 10-32 to 10-32 mounting stud

Optional accessories: 340-XXX Cable Assembly, #32 AWG, -54 to +121°C (XXX designates length in inches, 5ft standard)
 343-XXX Cable Assembly, #28 AWG, -40 to +85°C (XXX designates length in inches, 5ft standard)
 101 Three Channel DC Signal Conditioner Amplifier

The information in this sheet has been carefully reviewed and is believed to be accurate; however, no responsibility is assumed for inaccuracies. Furthermore, this information does not convey to the purchaser of such devices any license under the patent rights to the manufacturer. Measurement Specialties, Inc. reserves the right to make changes without further notice to any product herein. Measurement Specialties, Inc. makes no warranty, representation or guarantee regarding the suitability of its product for any particular purpose, nor does Measurement Specialties, Inc. assume any liability arising out of the application or use of any product or circuit and specifically disclaims any and all liability, including without limitation consequential or incidental damages. Typical parameters can and do vary in different applications. All operating parameters must be validated for each customer application by customer's technical experts. Measurement Specialties, Inc. does not convey any license under its patent rights nor the rights of others.

ordering info

PART NUMBERING Model Number+Range

4801A-GGGG

|
 | _____ Range (0010 is 10g)

Example: 4801A-0010
 Model 4801A, 10g