

Cable-Extension Position Transducer

CANbus • SAE J1939

Ranges: 0-10 to 0-250 inches

Industrial Grade • High Cycle Applications

PT5CN

Specification Summary:

GENERAL

Full Stroke Ranges 0-10 to 0-250 inches
 Electrical Interface CANbus SAE J1939
 Protocol Proprietary B
 Accuracy $\pm 0.25\%$ to $\pm 0.10\%$ full stroke
 Repeatability $\pm 0.02\%$ full stroke
 Resolution $\pm 0.003\%$ full stroke
 Measuring Cable stainless steel or thermoplastic
 Enclosure Material hard anodized aluminum
 Sensor plastic-hybrid precision potentiometer
 Potentiometer Cycle Life *see ordering information*
 Maximum Retraction Acceleration *see ordering information*
 Weight 5 lbs. max.

ELECTRICAL

Input Voltage 7 - 18 VDC
 Input Current 60 mA max.
 Baud Rate 125K, 250K, or 500K via DIP switches

ENVIRONMENTAL

Environmental Suitability NEMA 4/6, IP 65/67
 Operating Temperature -40° to 185° F (-40° to 85° C)
 Vibration up to 10 G's to 2000 Hz maximum



The PT5CN cable extension position transducer communicates linear position via the CANbus SAE J1939 interface providing a precision position feedback to your PLC. The PT5DN is offered in full stroke ranges up to 250 inches and a thermoplastic measuring cable for high cycle and rugged applications.

Because the PT5CN uses a potentiometer as its sensing element, the position signal is “absolute” and does not have to be reset to a “home” position upon startup.

Outline Drawing

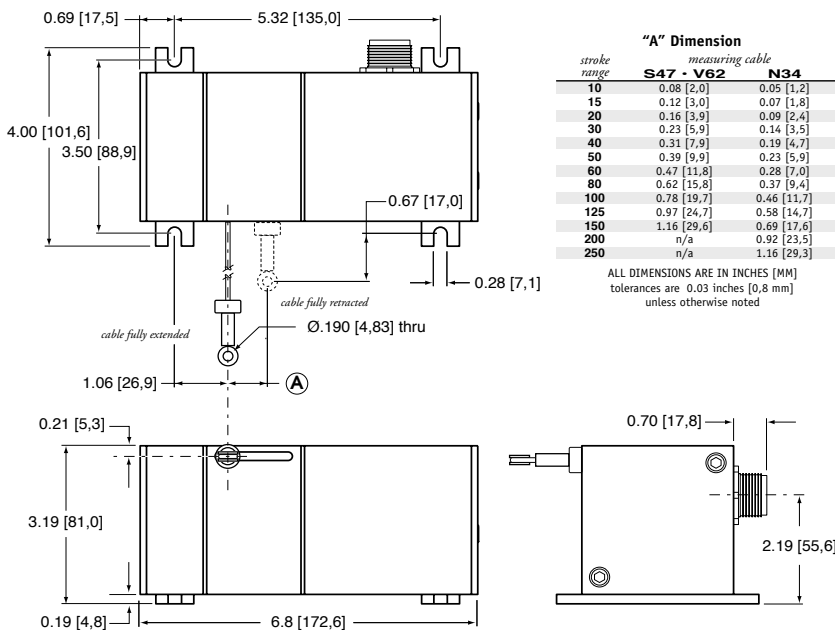

Output Signal

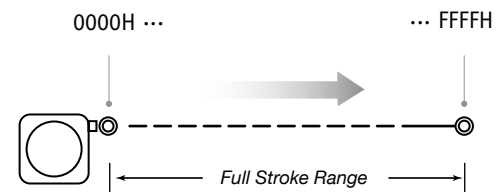

I/O Format:

Data Frame

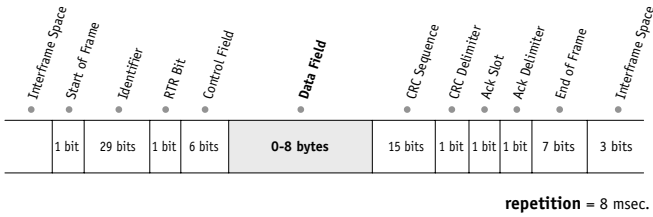

Data Field

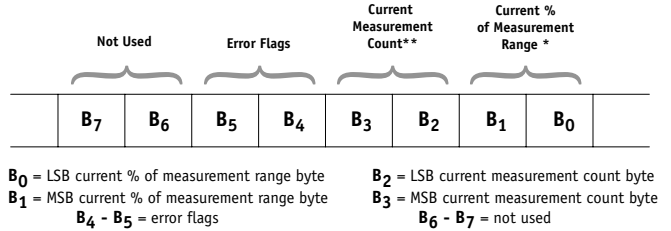

***Current % of Measurement Range**

The Current % of Measurement Range is a 2-byte value that expresses the current linear position as a percentage of the entire full stroke range. Resolution is .1 % of the full stroke measurement range.

This value starts at **0000H** at the beginning of the stroke and ends at **03E8H**.

Example:

Hex	Decimal	Percent
0000	0000	0.0%
0001	0001	0.1%
0002	0002	0.2%
...
03E8	1000	100.0%

****Current Measurement Count**

The Current Measurement Count (CMC) is the output data that indicates the present position of the measuring cable.

The CMC is a 16-bit value that occupies bytes **B₀** and **B₁** of the data field. **B₀** is the **LSB** (least significant byte) and **B₁** is the **MSB** (most significant byte).

The CMC starts at **0000H** with the measuring cable fully retracted and continues upward to the end of the stroke range stopping at **FFFFH**. This holds true for all ranges.

Converting CMC to Inches

If required, the CMC can easily be converted a linear measurement expressed in inches instead of just counts.

This is accomplished by first dividing the CMC by 65,535 (total counts over the range) and then multiplying that value by the FSR:

$$\left(\frac{\text{CMC}}{65,535} \right) \times \text{FSR}$$

Example:

If the full stroke range is **30 inches** and the current position is **OFF2 Hex** (4082 Decimal) then,

$$\left(\frac{4082}{65,535} \right) \times 30.00 \text{ inches} = 1.87 \text{ inches}$$

Setting the Address Setting (Node ID) and Baud Rate

Address Setting (Node ID)

The Address Setting (Node ID) is set via 6 switches located on the 8-pole DIP switch found on the DeviceNET controller board located inside the transducer.

The DIP switch settings are binary starting with switch number **1** (= 2⁰) and ending with switch number **6** (= 2⁵).

DIP-1 (2 ⁰)	DIP-2 (2 ¹)	DIP-3 (2 ²)	DIP-4 (2 ³)	DIP-5 (2 ⁴)	DIP-6 (2 ⁵)	address (decimal)
0	0	0	0	0	0	0
1	0	0	0	0	0	1
0	1	0	0	0	0	2
...
1	1	1	1	1	1	63



Baud Rate

The transmission baud rate may be either factory preset at the time of order or set manually at the time of installation.

The baud rate can be set using switches **7 & 8** on the 8-pole DIP switch found on the DeviceNET controller board located inside the transducer.

DIP-7	DIP-8	baud rate
0	0	125k
1	0	250k
0	1	500k
1	1	125k



CANBus Controller Board and DIP Switch Location

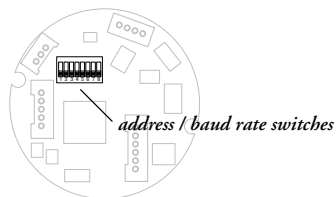

Caution! Do Not Remove Spring-Side End Cover
 removing spring-side end cover could cause spring to become unseated and permanently damaged.

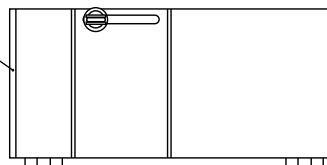

internal dip switches & controller board
 to gain access to the controller board, remove four Allen-Head Screws and remove end cover bracket.

Ordering Information:

Model Number:

PT5CN - - - - - **J** - - - -
order code: R A B C D E F

Sample Model Number:

PT5CN - 50 - S47 - FR - J - 500 - 32 - SC5

- R** range: 50 inches
- A** measuring cable: .047 stainless steel
- B** measuring cable exit: front
- C** interface: CANbus SAE J1939
- D** baud rate: 500 k bits/sec.
- E** node ID: 32 decimal
- F** electrical connection: 5-meter cordset with straight plug

Full Stroke Range:

R order code:	10	15	20	25	30	40	50	60	80	100	125	150	200	250
full stroke range, min:	10 in.	15 in.	20 in.	25 in.	30 in.	40 in.	50 in.	60 in.	80 in.	100 in.	125 in.	150 in.	200 in.	250 in.
accuracy (% of f.s.):	0.25%					0.15%					0.10%			
potentiometer cycle life:	2,500,000 cycles					500,000 cycles					250,000 cycles			
cable tension (20%):	41 ounces										21 ounces			
max. cable velocity/acceleration:	300 in./sec • 5 G's										120 in./sec • 2 G's			

Measuring Cable:

A order code:	N34	S47	V62
	.034 nylon-coated stainless steel <i>available in all ranges</i>	.047 stainless steel <i>all ranges up to 150 inches</i>	.062 thermoplastic <i>all ranges up to 150 inches</i>

Cable Exit:

B order code:	UP	DN	FR	BK
direction:	up	down	front	back
	inches [mm]			

Baud Rate:

D order code:	125	250	500
	125 kbaud	250 kbaud	500 kbaud



Node ID:

E order code:	0	1	2	...	62	63
	select address (0 - 63 Decimal)					

Ordering Information (cont.)

Electrical Connection:

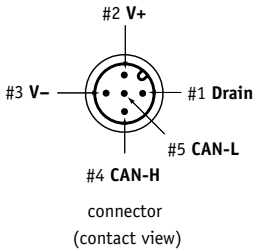
① order code:

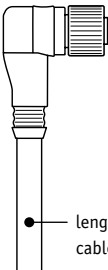
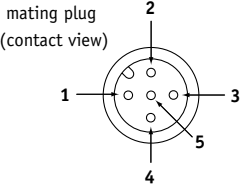
blank	MC5	SC5	NC5																		
5-pin micro-connector (no mating plug supplied)	5-pin micro-connector w/ mating plug	5-pin micro-connector and 5 meter length cordset w/straight mating plug	5-pin micro-connector and 5 meter length cordset w/90° mating plug																		
 <p>#2 V+ #3 V- #1 Drain #5 CAN-L #4 CAN-H connector (contact view)</p>	 <p>0.16" - 0.32" OD Cable (THIN)</p>	 <p>length: 16ft [5M] cable: Thin</p>	 <p>length: 16ft [5M] cable: Thin</p>																		
	 <p>mating plug (contact view)</p>	<table border="1"> <thead> <tr> <th>pin</th> <th>signal</th> <th>wire color</th> </tr> </thead> <tbody> <tr> <td>1</td> <td>drain</td> <td>brown</td> </tr> <tr> <td>2</td> <td>V+</td> <td>white</td> </tr> <tr> <td>3</td> <td>V-</td> <td>blue</td> </tr> <tr> <td>4</td> <td>Can-H</td> <td>black</td> </tr> <tr> <td>5</td> <td>Can-L</td> <td>grey</td> </tr> </tbody> </table>	pin	signal	wire color	1	drain	brown	2	V+	white	3	V-	blue	4	Can-H	black	5	Can-L	grey	
pin	signal	wire color																			
1	drain	brown																			
2	V+	white																			
3	V-	blue																			
4	Can-H	black																			
5	Can-L	grey																			

version: 2.0 last updated: March 30, 2005