

Cable-Extension Position Transducer

CANbus • SAE J1939

Ranges: 0-75 to 0-550 inches

Industrial Grade

PT9CN

Specification Summary:

GENERAL

Full Stroke Range Options—on this datasheet 0-75 to 0-550 inches
 Electrical Signal Interface CANbus SAE J1939
 Protocol Proprietary B
 Accuracy $\pm 0.10\%$ full stroke
 Repeatability $\pm 0.02\%$ full stroke
 Resolution $\pm 0.003\%$ full stroke
 Measuring Cable Options nylon-coated stainless steel or thermoplastic
 Enclosure Material powder-painted aluminum or stainless steel
 Sensor plastic-hybrid precision potentiometer
 Potentiometer Cycle Life 250,000, min. —before signal degradation can occur
 Maximum Retraction Acceleration see ordering information
 Maximum Velocity see ordering information
 Weight, Aluminum (Stainless Steel) Enclosure 8 lbs. (16 lbs.) max.

ELECTRICAL

Input Voltage 7 - 18 VDC
 Input Current 60 mA max.
 Address Setting/Node ID 0...63 set via DIP switches
 Baud Rate 125K, 250K or 500K set via DIP switches

ENVIRONMENTAL

Enclosure NEMA 4/4X/6, IP 67
 Operating Temperature -40° to 200° F (-40° to 90° C)
 Vibration up to 10 G's to 2000 Hz maximum



The PT9CN communicates linear position feedback via the CANbus SAE J1939 interface. The PT9CN has been designed for factory and harsh environment applications requiring full stroke ranges up to 550".

As a member of Celesco's innovative family of NEMA 4 rated cable-extension transducers, the PT9CN installs in minutes by simply mounting its body to a fixed surface and attaching its cable to the movable object. Perfect parallel alignment not required.

Fig. 1 – Outline Drawing (26 oz. cable tension only)

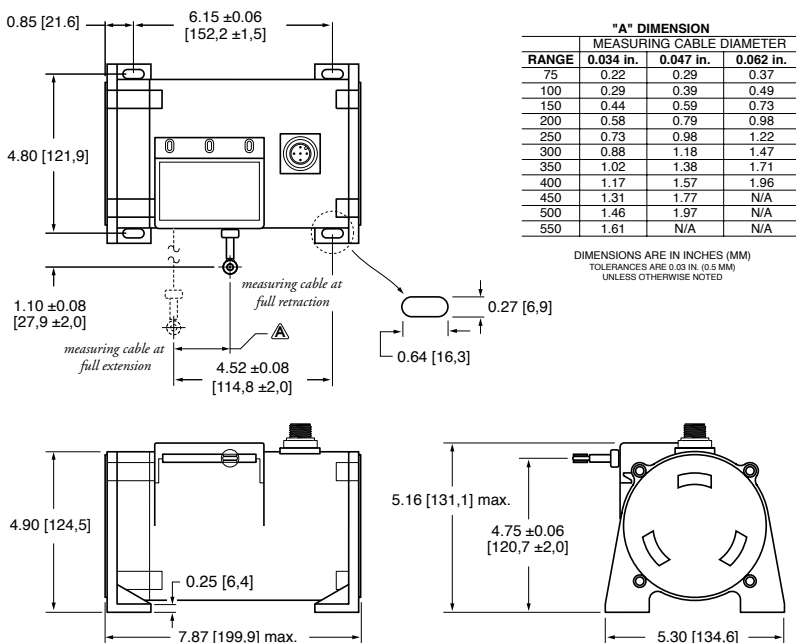

Output Signal

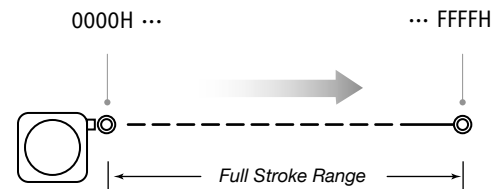

I/O Format:

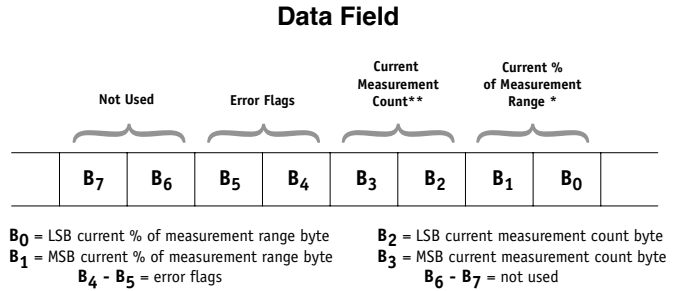
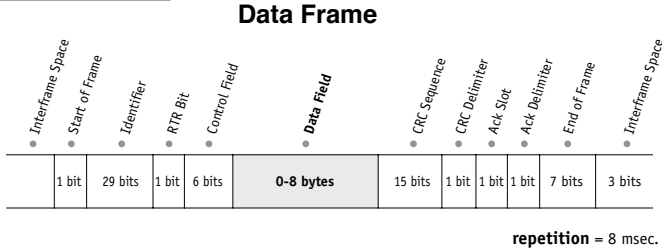

***Current % of Measurement Range**

The Current % of Measurement Range is a 2-byte value that expresses the current linear position as a percentage of the entire full stroke range. Resolution is .1 % of the full stroke measurement range.

This value starts at 0000H at the beginning of the stroke and ends at 03E8H.

Example:

Hex	Decimal	Percent
0000	0000	0.0%
0001	0001	0.1%
0002	0002	0.2%
...
03E8	1000	100.0%

****Current Measurement Count**

The Current Measurement Count (CMC) is the output data that indicates the present position of the measuring cable.

The CMC is a 16-bit value that occupies bytes **B₀** and **B₁** of the data field. **B₀** is the LSB (least significant byte) and **B₁** is the MSB (most significant byte).

The CMC starts at 0000H with the measuring cable fully retracted and continues upward to the end of the stroke range stopping at FFFFH. This holds true for all ranges.

Converting CMC to Inches

If required, the CMC can easily be converted a linear measurement expressed in inches instead of just counts.

This is accomplished by first dividing the CMC by 65,535 (total counts over the range) and then multiplying that value by the FSR:

$$\left(\frac{\text{CMC}}{65,535} \right) \times \text{FSR}$$

Example:

If the full stroke range is 30 inches and the current position is OFF2 Hex (4082 Decimal) then,

$$\left(\frac{4082}{65,535} \right) \times 30.00 \text{ inches} = 1.87 \text{ inches}$$

Setting the Address Setting (Node ID) and Baud Rate

Address Setting (Node ID)

The Address Setting (Node ID) is set via 6 switches located on the 8-pole DIP switch found on the DeviceNET controller board located inside the transducer.

The DIP switch settings are binary starting with switch number 1 (= 2⁰) and ending with switch number 6 (= 2⁵).

DIP-1 (2 ⁰)	DIP-2 (2 ¹)	DIP-3 (2 ²)	DIP-4 (2 ³)	DIP-5 (2 ⁴)	DIP-6 (2 ⁵)	address (decimal)
0	0	0	0	0	0	0
1	0	0	0	0	0	1
0	1	0	0	0	0	2
...
1	1	1	1	1	1	63



Baud Rate

The transmission baud rate may be either factory preset at the time of order or set manually at the time of installation.

The baud rate can be set using switches 7 & 8 on the 8-pole DIP switch found on the DeviceNET controller board located inside the transducer.

DIP-7	DIP-8	baud rate
0	0	125k
1	0	250k
0	1	500k
1	1	125k



CANBus Controller Board and DIP Switch Location

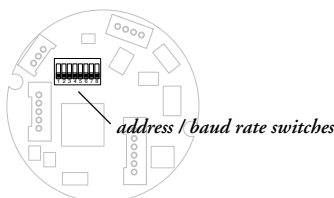

Caution! Do Not Remove Spring-Side End Cover
 removing spring-side end cover could cause spring to become unseated and permanently damaged.

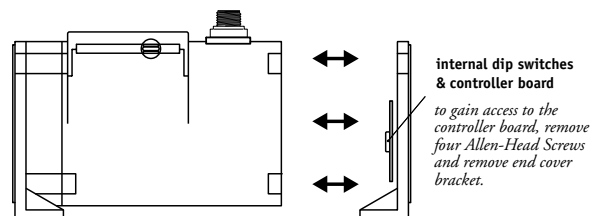

Ordering Information:

Node ID:

Ⓜ order code:	0	1	2	3	...	61	62	63
	select address (0 - 63 Decimal)							

Electrical Connection:

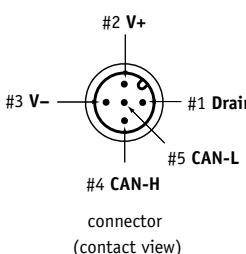
Ⓜ order code:	blank	MC5	SC5	NC5																		
	5-pin micro-connector (no mating plug supplied)	5-pin micro-connector w/ mating plug	5-pin micro-connector and 5 meter length cordset w/straight mating plug	5-pin micro-connector and 5 meter length cordset w/90° mating plug																		
	 <p>connector (contact view)</p>	 <p>0.16" - 0.32" OD Cable (THIN)</p>	 <p>length: 16ft [5M] cable: Thin</p>	 <p>length: 16ft [5M] cable: Thin</p>																		
		 <p>mating plug (contact view)</p>																				
			<table border="1"> <thead> <tr> <th>pin</th> <th>signal</th> <th>wire color</th> </tr> </thead> <tbody> <tr> <td>1</td> <td>drain</td> <td>brown</td> </tr> <tr> <td>2</td> <td>V+</td> <td>white</td> </tr> <tr> <td>3</td> <td>V-</td> <td>blue</td> </tr> <tr> <td>4</td> <td>Can-H</td> <td>black</td> </tr> <tr> <td>5</td> <td>Can-L</td> <td>grey</td> </tr> </tbody> </table>	pin	signal	wire color	1	drain	brown	2	V+	white	3	V-	blue	4	Can-H	black	5	Can-L	grey	
pin	signal	wire color																				
1	drain	brown																				
2	V+	white																				
3	V-	blue																				
4	Can-H	black																				
5	Can-L	grey																				

Fig. 2 – Outline Drawing (42 oz. cable tension only)

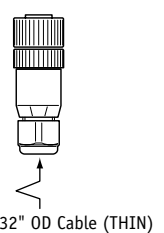
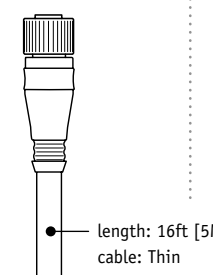
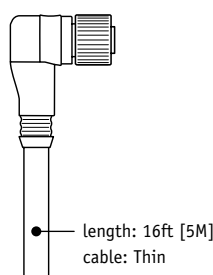
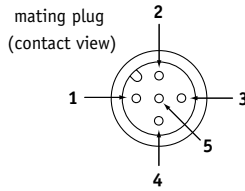
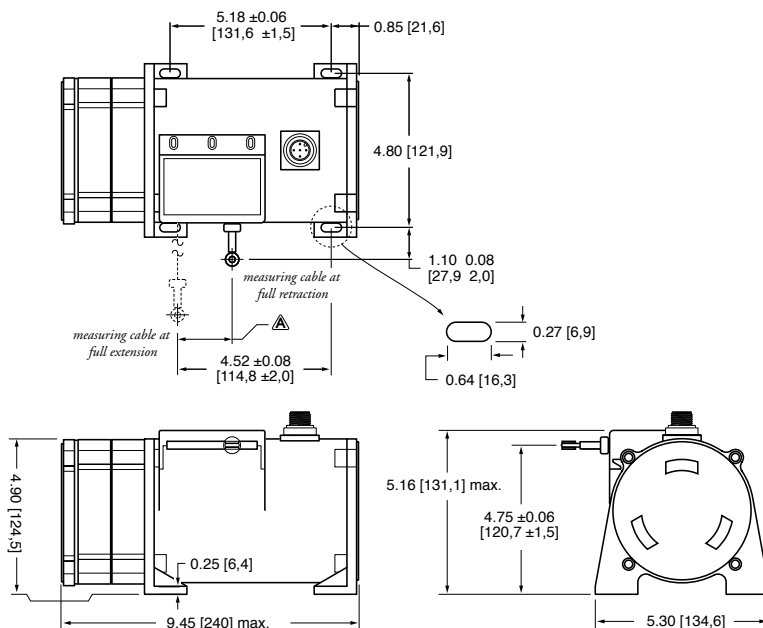

version: 4.0 last updated: June 7, 2005